



STL RET

| LED Street Light Retrofit |

Construction

Mogul or Edison Base
Heat Wick® heat sink technology

Operating Ranges

Operating temperature range of -40 to 140°F
Operating humidity range of 10-99%
13' to 15' application heights
150W HID or lower replacement

CLGL Design

No hazardous substances. ROHS compliant.
No Mercury. No Lead.

Applications

Street Lighting, Parking Lot Lighting, Area Lighting,
Perimeter and Security Lighting

Model Details

Wattage	31
Lumens	2077
Approximate Weight	3 lbs. 9 oz.
Warranty	5 Year

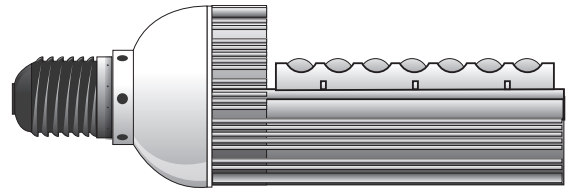
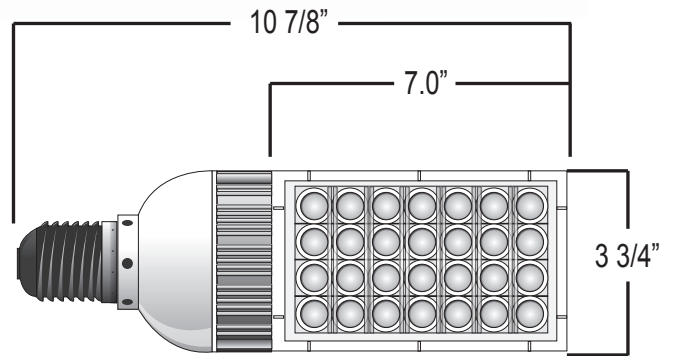
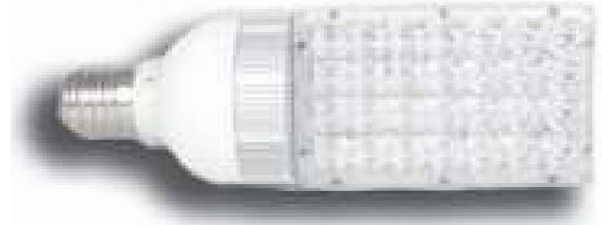

Ordering Information

Please Fill Out Below

Model : STLRET

Quantity

Lamp Base

E27 or E40

Voltage

90V-265V, 277V*, 347V*
*using a step down transformer

Lamp Color

5000K-6000K
custom CCT ranges available