



# CLGL - FLOOD 05

| U-Bracket Mounting Spot Light |

## Construction

Aluminum alloy housing  
Glass lens. IP 65.  
5500 K standard  
10 Year Warranty on housing

## Operating Ranges

Operating temperature range of -40 to 140°F  
Operating humidity range of 10 - 99%



## CLGL Design

24 hr run hard design  
No hazardous substances. ROHS compliant.  
No mercury. No lead.

## Applications

Perimeter, Security, Area, Flood & Spot Lighting

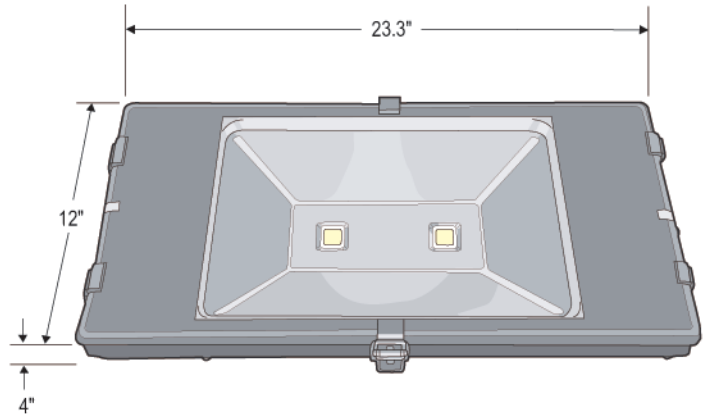

## Model Details

Wattage	152
Lumens	11415
Approximate Weight	14 lbs. 3 oz.
Warranty	7 Year

## Ordering Information

Please Fill Out Below

Model : FLOOD 05

**Lamp Quantity**

**Voltage**

90-265, 277V\*, 347V\*, 480V\*  
\*using a step down transformer

**Lamp Color**

4100K, 5500K, Custom Colors  
Available

**Base Angle**