



Construction

Aluminum alloy housing
Glass lens. IP 65.
5500 K standard
10 Year Warranty on housing

Operating Ranges

Operating temperature range of -40 to 140°F
Operating humidity range of 10 - 99%

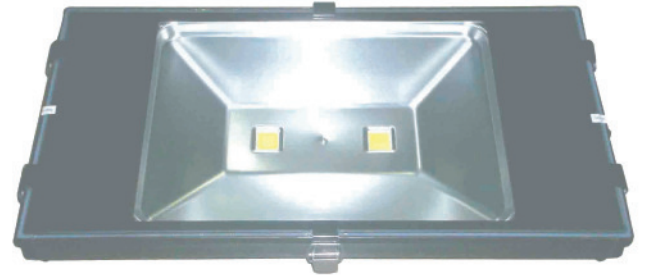

CLGL Design

24 hr run hard design
No hazardous substances. ROHS compliant.
No mercury. No lead.

Applications

Perimeter, Security, Area, Flood & Spot Lighting

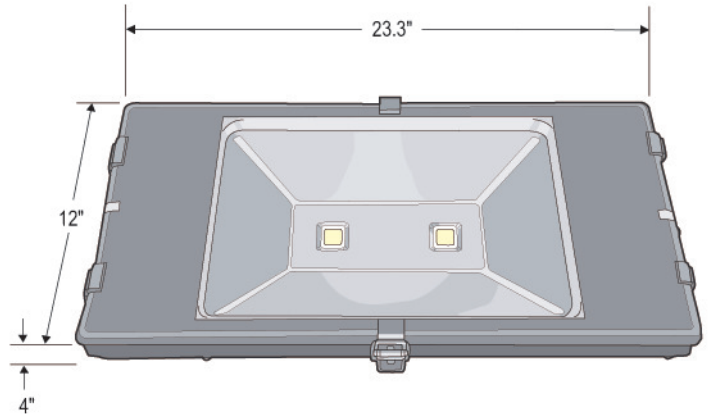

Model Details

Wattage	86
Lumens	6459
Approximate Weight	9 lbs. 3 oz.
Warranty	7 Year

Ordering Information

Please Fill Out Below

Model : FLOOD 02

Lamp Quantity

Voltage

90-265, 277V*, 347V*, 480V*
*using a step down transformer

Lamp Color

4100K, 5500K, Custom Colors
Available

Base Angle