



CLW 70

| 250 - 320 W Warehouse Lighting |

Construction

- 100% recyclable materials
- Hook & eye hanging system
- IP rating 65
- Revolutionary 70 W Chip Array
- Heat Wick® heat sink technology

Operating Ranges

- Operating temperature range of - 40 to 140°F
- Operating humidity range of 10 - 99%

CLGL Design

- 24 hr run hard design
- No hazardous substances. ROHS compliant.
- No mercury. No lead.
- No on / off hour rating specifications
- Works with existing occupancy sensing technology

Applications

- Warehouse, Manufacturing, Parking Garage,
- Convention Space Lighting, Lobby Lighting

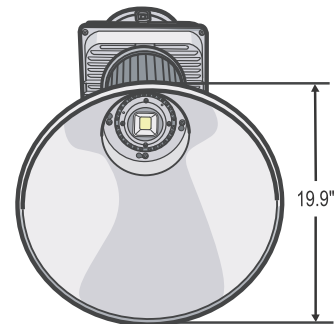
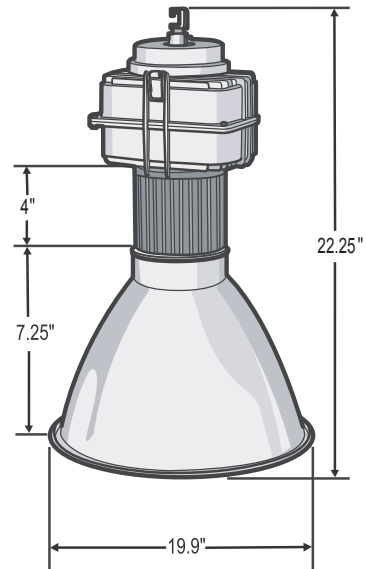

Model Details

Wattage	76
Lumens	5179
Effective Lumen Output	320W
Approximate Weight	5 lbs. 0 oz.
Warranty	5 Year

Ordering Information

Please Fill Out Below

Model : CLW 70

Lamp Quantity

Hood Options

(LB-Low Bay wide, HB-High Bay pointed distribution, AC - acrylic ring)

Voltage

120V -240V, 277V -347V

Lamp Color

4100K, 5500K