



CLGL WP88

| 400W HID EQ. |

Construction

Aluminum alloy housing. Glass lens.
5600K Standard
110-240V Standard
10 Year warranty on housing
Heat Wick® heat sink technology

Specifications

Operating temperature range of - 40 to 140°F
Operating humidity range of 10 - 99%
UL Approved

CLGL Design

24 hr run hard design
No hazardous substances. ROHS compliant.
No mercury. No lead.

Applications

Outdoor Lighting, Under Canopy Lighting, Parking Garages,
Security, Area and Perimeter Lighting

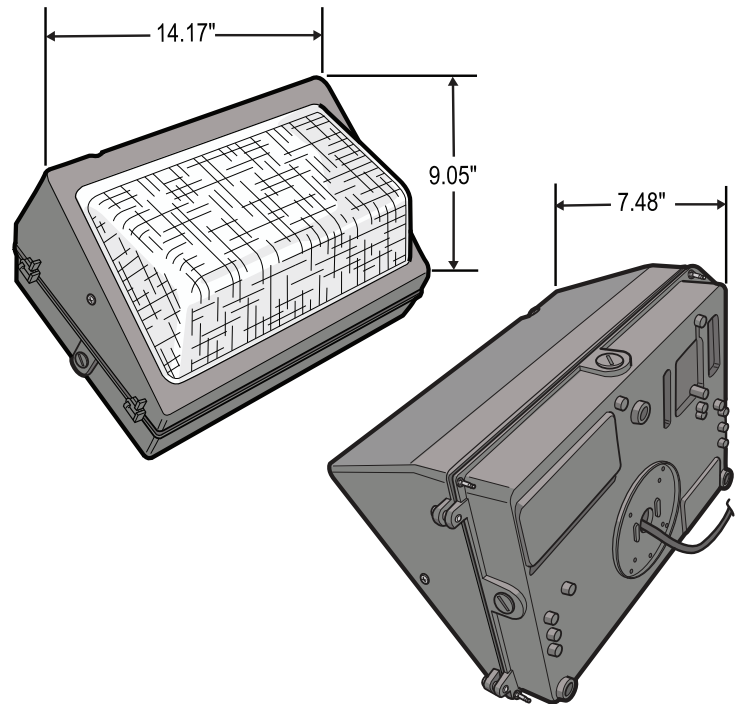

Model Details

Wattage	80
Lumens	3224
Approximate Weight	11 lbs. 11 oz.
Approximate Length	14 inches
Warranty	7 Year



UL Listed



Manufactured In The USA

Ordering Information

Please Fill Out Below

Model : CLGL WP88

Lamp Quantity

Voltage

Lamp Color

110V- 277V, 100V -277V, 347V*
*Using a step down transformer

5600K
Custom Colors Available