



Construction

Aluminum alloy housing. Glass lens.
5750K Standard
110-240V Standard
10 Year warranty on housing
Heat Wick® heat sink technology

Specifications

Operating temperature range of - 40 to 140°F
Operating humidity range of 10 - 99%
UL Approved

CLGL Design

24 hr run hard design
No hazardous substances. ROHS compliant.
No mercury. No lead.

Applications

Outdoor Lighting, Under Canopy Lighting, Parking Garages,
Security, Area and Perimeter Lighting

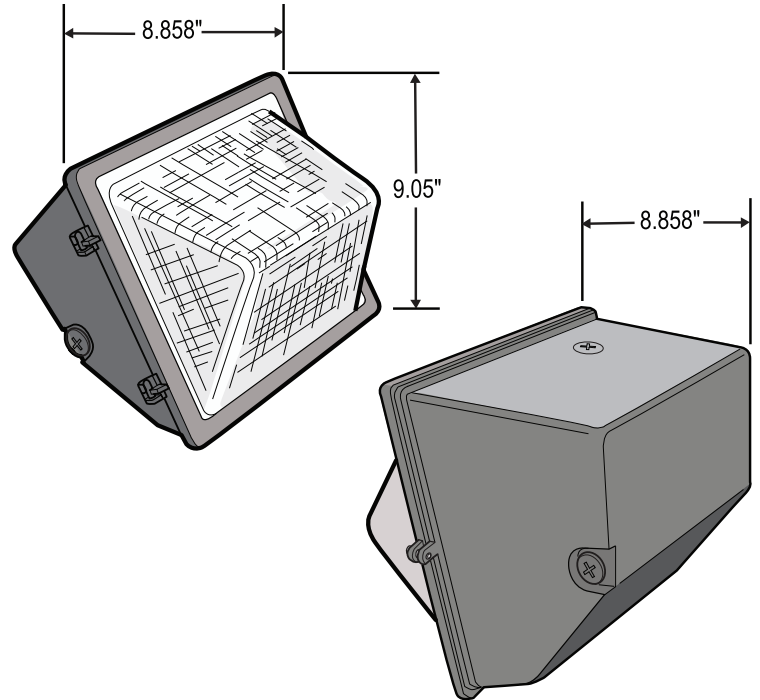

Model Details

Wattage	17
Lumens	850
Approximate Weight	4 lbs. 2 oz.
Approximate Length	9 inches
Warranty	7 Year



UL Listed



Manufactured In The USA

Ordering Information

Please Fill Out Below

Model : CLGL WP15

Lamp Quantity

Voltage

120V, 240V, 277V, 347V*
*Using a step down transformer

Photo Cell

Yes or No

Lamp Color

5750K
Custom Colors Available

Lens

Glass Lens: Standard (G),
Acrylic Lens: Optional (A)