



## Product Description

The CLGL Emergency Battery Backup System is designed to work with CLGL & other LED systems. Utilizing a compact battery system to run the LED system for a specified amount of time in the event power is absent in the circuit.

## Performance Summary

CLGL Battery Backup Systems use Ni-MH batteries, the same kind used in Hybrid Cars. Our systems are built with a smart charging system to extend battery life and prevent over charging.

## Specifications and Features

The flame retardant PC encased controller is built with a smart charging system as well as a heat based sensing system for optimal performance in all environments. The ni-MH batteries are CE/ROHS and UL Listed.

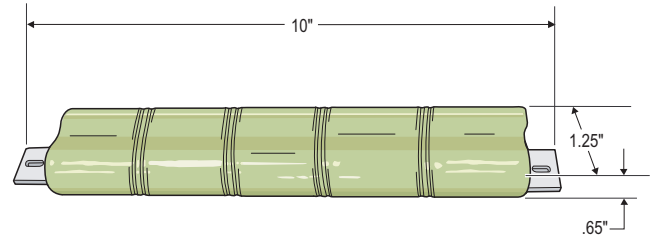

- 30 Minute Battery -

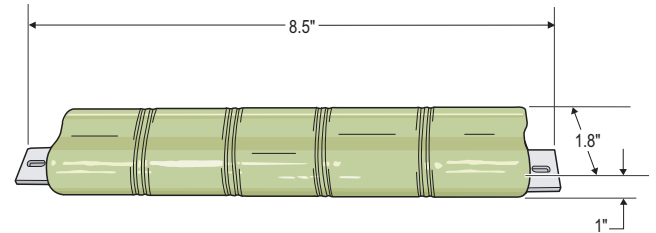

- 60 / 90 Minute Battery -

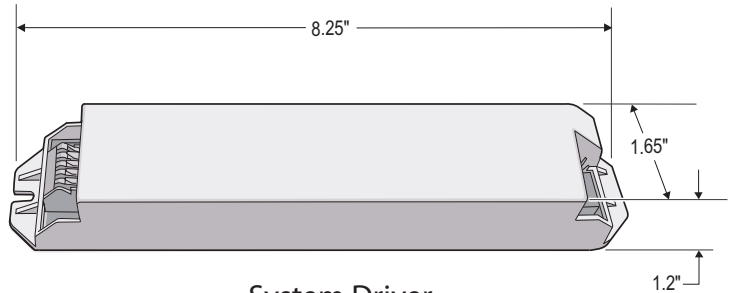

- System Driver -

## Model Details

Battery	Ni-MH
Wattage	18W
Temperature Range	14 - 113° F
Humidity Range	0 - 80%
Warranty	3 Year

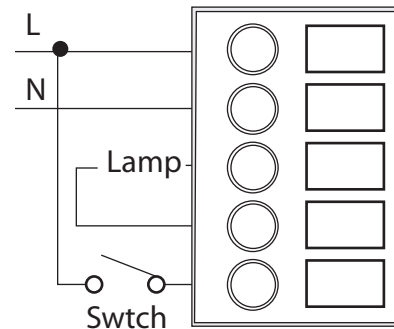

## Ordering Information

Please Fill Out Below

Model : CLGL - EBS

**Quantity**

**Voltage**

90 - 277V

**Battery Run Time**

30 / 60 / 90 Minutes